

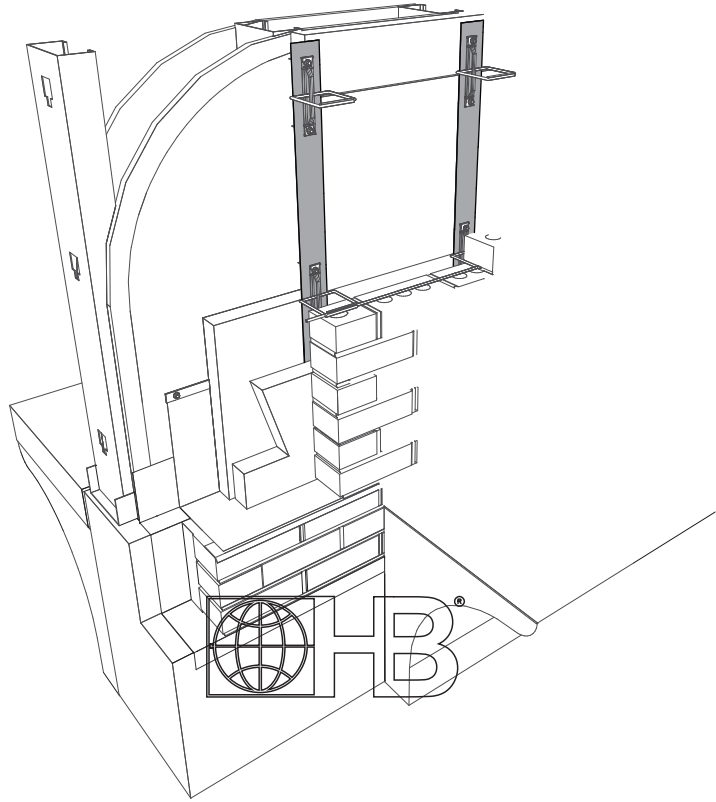

**HOHMANN & BARNARD, INC.**  
A MiTek - BERKSHIRE HATHAWAY COMPANY

# Flashing and Reglets X-SEAL™ Tape

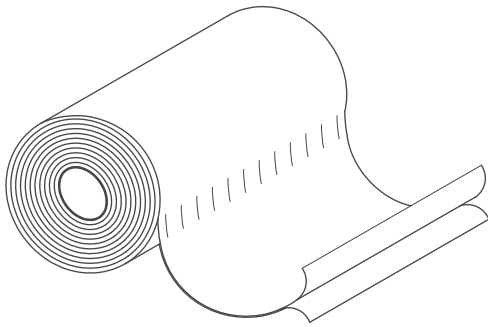

DRAWINGS FOR ILLUSTRATIVE PURPOSES ONLY

### X-Seal Transition Anchor Tape

for X-Seal® Veneer Anchor

Seals around the shaft of the screw and legs of X-Seal™ Anchors at the point of penetration. X-SEAL Tape has been designed to be applied in continuous lengths only. It can also be used as an insulation joint tape.

- Reinforced polyolefin base, laminated to a polypropylene layer.
- Adhesive-backed with removable release liner
- UV resistant for up to 90 days

Patents Pending

### Storage and Protection:

X-SEAL Tape should be stored between 40°F (5°C) and 100°F (38°C). If exposed to lower temperatures, restore product to a minimum of 40° F (5° C) before application.

**Manufactured from 45% post-industrial and/or post-consumer recycled material.**

**\* Please refer to Hohmann & Barnard installation instructions for more information.**

### Technical Data:

- Tensile Strength - **ASTM D751-95**  
Machine Direction (Force) 130 lbs  
Cross Direction (Force) 124 lbs
- Trapezoidal Tear Strength - **ASTM D4533-91**  
Machine Direction (Force) 46 lbs  
Cross Direction (Force) 44 lbs
- Mullen Burst - **ASTM D751-95** 180 psi
- UV Exposure (2000 hours) - **ASTM G154-98** >90%
- Permeability  
MVTR - **ASTM E96 - B** <.075 Perms<sup>1</sup>  
Air permeability - **TAPPI-460** >5000 Sec/100cc

**Size:** 3" wide x 75' long

<sup>1</sup>Grains/h/ft<sup>2</sup>/in Hg (perms)

**HOHMANN & BARNARD, Inc.**  
30 Rasons Court | Hauppauge, NY 11788  
CORPORATE HEADQUARTERS  
T: 800.645.0616 F: 631.234.0683  
**www.h-b.com**

**Branch/Subsidiary Locations:**  
ALABAMA - ILLINOIS - MARYLAND  
NEW YORK - PENNSYLVANIA - TEXAS  
CANADA

© HOHMANN & BARNARD, INC. - 2013