

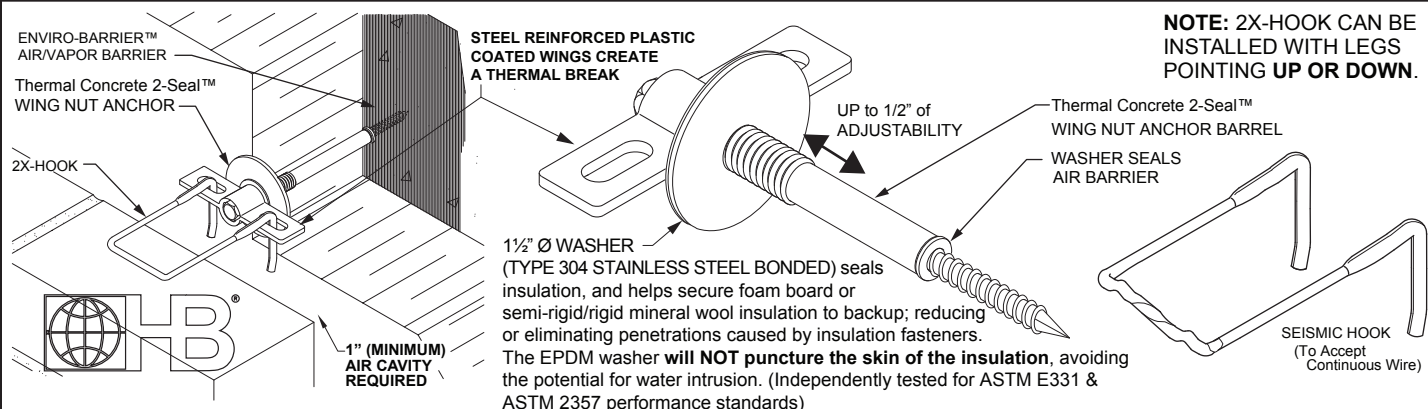

Veneer Anchors

Thermal Concrete 2-Seal™ Wing Nut Anchor Adjustable Thermal Veneer Anchor



Hohmann & Barnard's 2X-Hook has been tested and designed to withstand over 200-lbf, in tension or compression, at maximum allowed offset (TMS 402/602-16 12.2.2.5.5.4) of 1/4" (disengagement of the pintle from the veneer anchor). These results exceed BIA recommendations and the capabilities of standard "round wire" hooks/pintles by over 100%, while maintaining the ASTM A1064/1064M wire specification.

2-SEAL WING NUT WITH 2X-HOOKS (WORKING LOAD*)

CAVITY	0" OFFSET	5/8" OFFSET	1 1/4" OFFSET	TEST
6 1/2"	704#	325#	251#	TENSION
6 1/2"	470#	273#	250#	COMPRESSION

* WORKING LOAD DETERMINED AT .05" DEFLECTION
Tests were completed for 4 1/2" insulation with 2" air cavity.

PULL-OUT VALUES (1 1/4" MIN. Embed)

4000 psi. Concrete	C-90 Hollow Block
810# (ultimate)	883# (ultimate)

DRAWINGS FOR ILLUSTRATIVE PURPOSES ONLY

H&B RECOMMENDS 16" X 16" SPACING

Thermal Concrete 2-Seal™ Wing Nut Tie
An innovative single screw veneer tie for concrete, CMU, or wood stud construction. Featuring a dual-diameter barrel with factory-installed EPDM washers to seal both the face of the insulation and the air/vapor barrier. Projecting **Thermal Wings are steel reinforced and coated with flame resistant plastic**, creating a thermal break, decreasing thermal transfer through rigid insulation. The Thermal Wings accept a standard or seismic hook, spin to easily orient pintles/hooks to masonry joints, and provides up to 1/2" of adjustability to account for variations in wall thickness. Made with a 5/16" hex head, install with a standard hex socket. **The extra large washer helps secure insulation to backup.**
Thermal Concrete 2-Seal™ Wing Nut Anchor: US Pat. No. 7,415,803
2X-Hook: U.S. Pat. No. 8,613,175
Barrel (Stainless Steel): ASTM A580/A580M - AISI Type 304
Screw (Carbon Steel): ASTM A510 (Carbon Steel)
ASTM C954 (1000-hour polymer coating)
Wire (Carbon Steel): Prefabricated from cold-drawn steel wire conforming to **ASTM A1064/A1064M**
Tensile Strength - 80,000 p.s.i. | Yield Point - 70,000 p.s.i. minimum
Zinc Coating: Hot-Dip Galv after fabrication: **ASTM A153/A153M-B (1.5 oz/ft²)**
Wire (Stainless Steel): ASTM A580/A580M - AISI Type 304 or Type 316
NOTE: Pre-drill a 5/32" (4 mm) hole into concrete, CMU, or masonry backup to a depth of 2" (51 mm).
NOTE: Some configurations are non-stock, contact your local sales manager for price, availability and lead times.

Thermal Concrete 2-Seal™ Wing Nut Anchor Barrel Finish:
 Stainless Steel - Type 304

Thermal Concrete 2-Seal™ Wing Nut Anchor Style*:
(Equal to thickness of insulation)
 5/8" 1" 1 1/2" 2" 2 1/2" 3" 3 1/2"
 4" 4 1/2" 5" 5 1/2" 6" 6 1/2"
***NOTE: This anchor requires a 1" (minimum) air cavity.**

Hook Finish:
 Hot-Dip Galvanized | Stainless Steel Type 304 Type 316

3/16"Ø Compressed Leg Hook Length:
 3" (300H-2X) 4" (400H-2X) 5" (500H-2X)
 6" (600H-2X) 7" (700H-2X)

Compressed Leg Seismic Hook: - Length (Model), 3/16"Ø (5mm) wire
 3" (300-S-2X) 4" (400-S-2X) 5" (500-S-2X)

Continuous Wire Finish: (Diameter 9 ga. 3/16"Ø)
 Hot-Dip Galvanized | Stainless Steel Type 304 Type 316

Note: H&B recommends Stainless Steel Wire Ties for maximum protection against corrosion.

IMPORTANT: Since each construction project is unique, the appropriate selection and use of any product contained herein must be determined by competent architects, engineers and other appropriate professionals who are familiar with the specific requirements of the project in question. This drawing and/or data sheet is the confidential and proprietary information of Hohmann & Barnard, Inc. and is not to be reproduced, copied or disclosed, in whole or in part, without the prior written consent of H&B.

HOHMANN & BARNARD, INC.
CORPORATE HEADQUARTERS
30 Rasons Ct.
Hauppauge, NY 11788
T: 800-645-0616 | www.h-b.com

Branch/Subsidiary Locations:
ALABAMA - ILLINOIS - MARYLAND
NEW YORK - PENNSYLVANIA - TEXAS
UTAH - CANADA

© 2013-2021