

Flashing and Reglets

Mighty-Flash™-SA

Self Adhering Stainless Steel Fabric Flashing

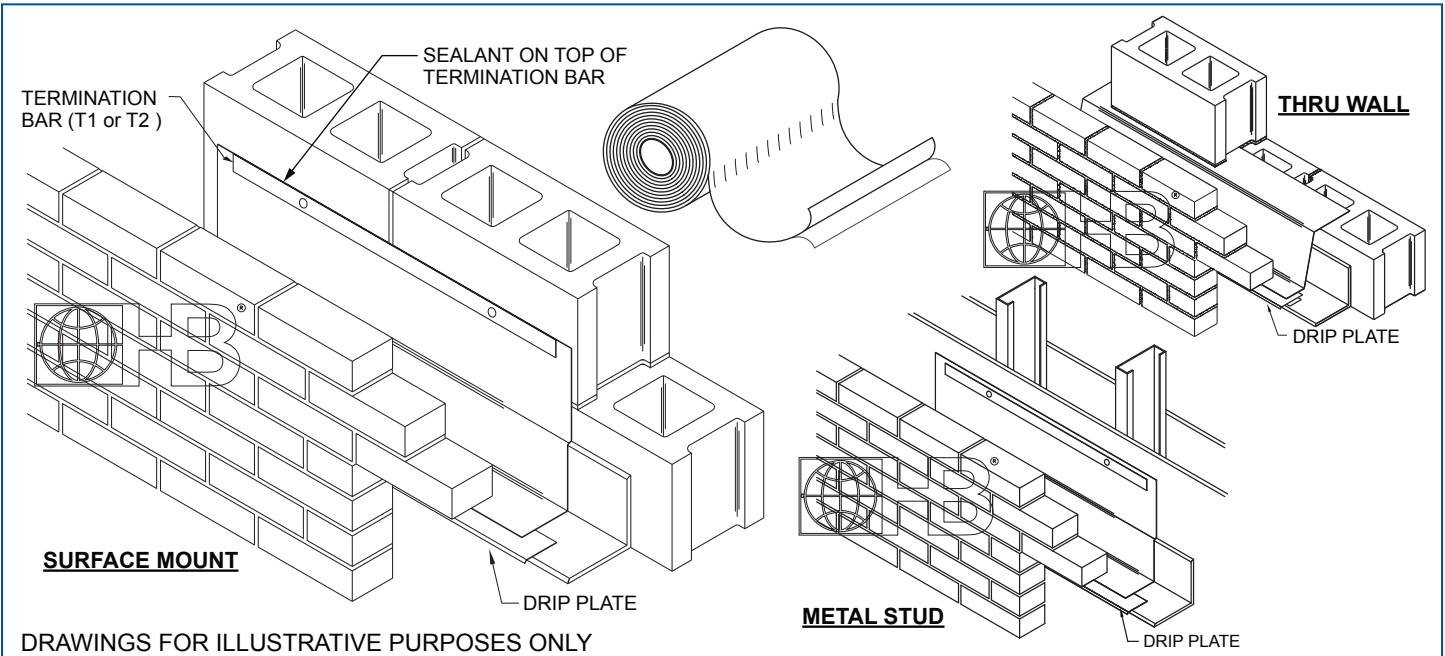

Technical Data:

| | | |
|----------------|------------|----------|
| Puncture (PSI) | ASTM E154 | 2,500+ |
| Tensile (PSF) | ASTM D412 | 100,000+ |
| Fire Resistant | ASTM E84 | Pass |
| Mold Resistant | ASTM D3273 | Pass |

Description & Benefits:

Mighty-Flash™-SA is a self-adhering stainless steel fabric flashing product with a removable release liner for easy application. The proprietary clear adhesive is factory-laminated to a Class A material consisting of a layer of polymeric fabric with a single sheet of Type 304 or 316 stainless steel bonded to one side. This innovative product is flexible and easy to form on the jobsite, features excellent puncture and tear resistance, and is designed to last for the life of the wall.

- Clear, non-asphaltic, pressure-sensitive, adhesive will not drool when exposed to UV or heat.
- An optional stainless steel drip edge is recommended to ensure diversion of moisture to outside of building (product can be cut flush with exterior wall)
- Surface mount applications should be attached with a stainless steel or aluminum termination bar
- Rolls are 60' long
- Membrane thickness .040 in. | Stainless Steel thickness: .030 in
- Available in 12", 16", 18", 24" & 36" widths
- Fire resistant: ASTM E84 tested, a Class A material
- Mold resistant: ASTM D3273 tested
- Heat resistant: no degradation in high heat applications
- UV-resistant for up to 180 days.
- Recyclable product with 60% Recycled Content
- Lifetime Warranty

Mighty-Flash™ SA flashing should be installed with white woven, printed material facing out.

*** Please refer to Hohmann & Barnard installation instructions for more information.**

Select Flashing Stainless Steel Type:

- Type 304 Stainless Steel
- Type 316 Stainless Steel (Special Marine Grade)

Width: (60 ft. rolls)

- 12" 16" 18" 24" 36"

Stainless Steel Drip Plate: (Recommended)

- 1 1/2" 3" Other _____

Flex-Flash® Drip Edge:

- 3"

Termination Bar:

- Stainless Steel (Type 304)
- Plastic

- Primer-SA** (5 gal. pail)
(Water-Based Primer for Self-Adhering Flashing)

- HB Sealant 1-Quart Tube**

- X-Seal Splice Tape** (4" wide)

IMPORTANT: Since each construction project is unique, the appropriate selection and use of any product contained herein must be determined by competent architects, engineers and other appropriate professionals who are familiar with the specific requirements of the project in question. This drawing and/or data sheet is the confidential and proprietary information of Hohmann & Barnard, Inc. and is not to be reproduced, copied or disclosed, in whole or in part, without the prior written consent of H&B.